

GENERAL ARRANGEMENT — HOLD
PLAN VIEW

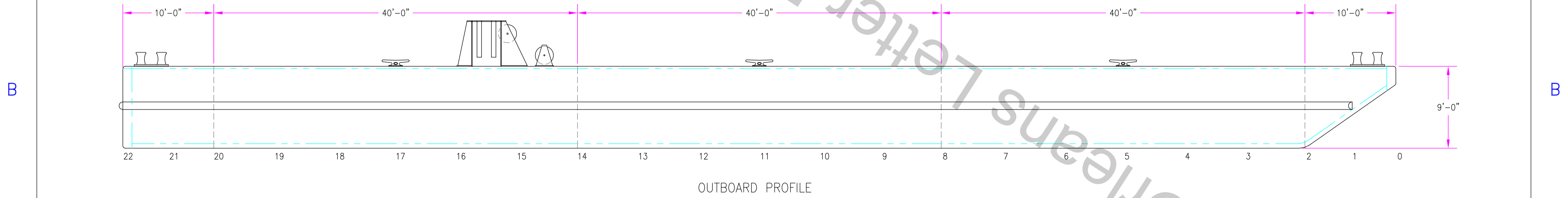

OUTBOARD PROFILE

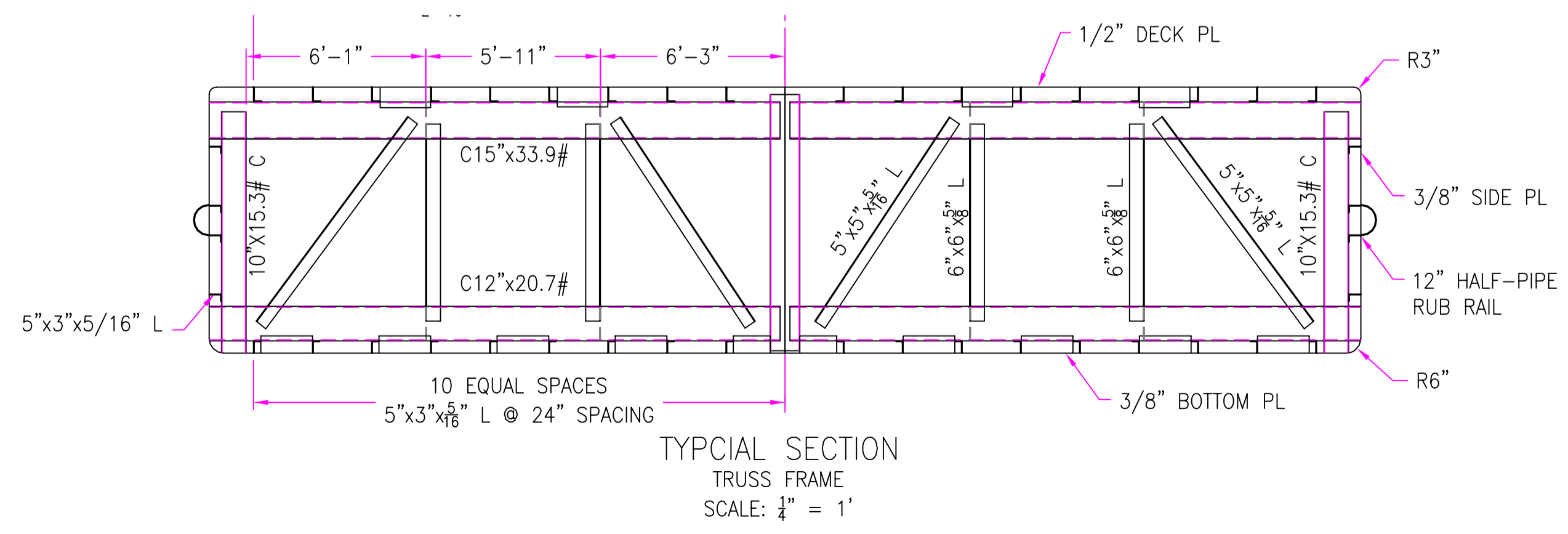

TYPICAL SECTION
TRUSS FRAME
SCALE: 1/4" = 1'

ALT	REVISION	DATE
3	- MODIFIED CENTERLINE BHD STIFF	06/06/12
2	- ADDED DOUBLER PLTS	05/05/12
1	- ADDED SPUD WELLS	04/16/12

THIS DRAWING/DOCUMENT IS CONFIDENTIAL AND THE PROPERTY OF FARRELL AND NORTON NAVAL ARCHITECTS AND MUST NOT BE USED FOR MANUFACTURE, COPIED OR COMMUNICATED TO ANY OTHER PERSON WITHOUT EXPRESS PERMISSION.

FARRELL & NORTON NAVAL ARCHITECTS
 NAVAL ARCHITECTS AND MARINE ENGINEERS
 PO BOX 66 NEWCASTLE, ME 04553
 (207) 563-3210 (TOM) (617) 308-1074 (GARRETT)

**GENERAL ARRANGEMENTS
AND PROFILE**

PROJECT: 140'x39'x9' DECK BARGE	
DRAWN BY: TMF	DATE: 02/29/12
APPROVED BY: GJN	SCALE: 3/16" = 1'
DWG #: B-264-02	ALT: 3